

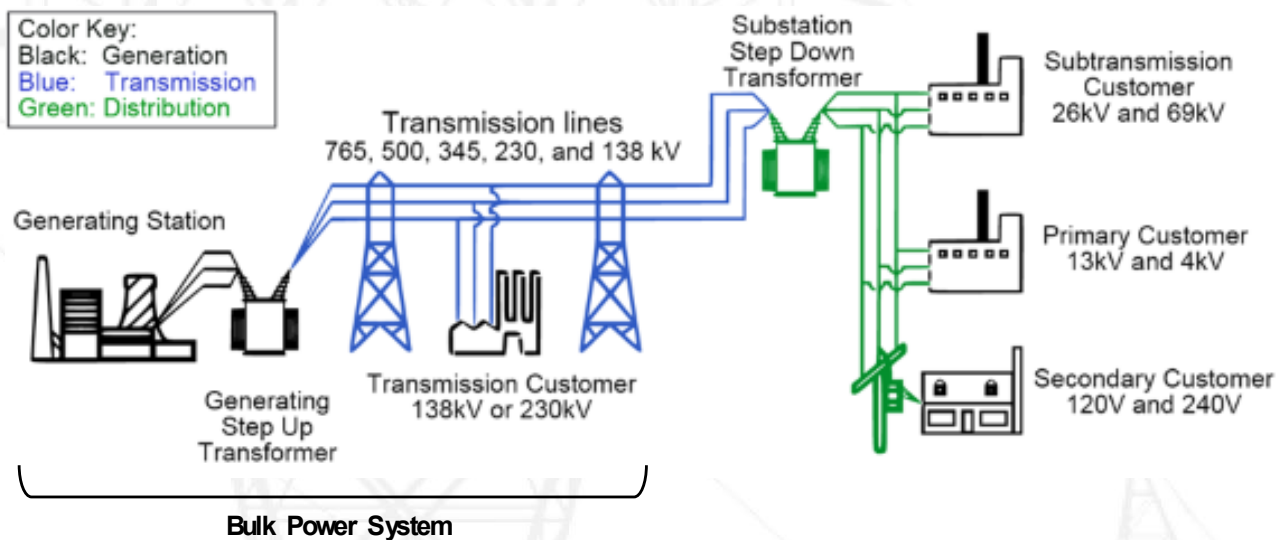

How the Bulk Power System Works

A reliable bulk power system is the lifeblood of our economy and is essential for the standard of living we enjoy today. Unlike water or gas, electricity cannot be stored in large quantities. It must be generated at the instant it is used, which requires supply be kept in constant balance with demand. Furthermore, electricity flows simultaneously over all transmission lines in the interconnected grid system in inverse proportion to their electrical resistance, so it generally cannot be routed over specific lines. This means generation and transmission operations in North America must be monitored and controlled in real-time, 24 hours a day, to ensure a reliable and continuous flow of electricity to homes and businesses. This requires the cooperation and coordination of hundreds of electricity industry participants.



* Source: [US-Canada Power System Outage Task Force](#)

This figure depicts the basic elements of the electricity system: how it is created at power generating stations and transported across high-voltage transmission and lower-voltage distribution lines to reach homes and businesses. Transformers at generating stations step the electric voltage up for efficient transport and then step the voltage down at substations to efficiently deliver power to customers. The generation and transmission components and their associated control systems comprise the “bulk power system.”

MRO Media Contacts:

Jessie Mitchell

Director of Communications

jessie.mitchell@mro.net

651-855-1733 | 651-238-7803

CLARITY

ASSURANCE

RESULTS